



HOUSEHAM

SELF-PROPELLED SPRAYERS



MERLIN™

Everything you want from
a sprayer. And more.



HOUSEHAM MERLIN™



Loaded with technology and practical features that make a real difference out in the field, the **MERLIN** embodies the very best of the pioneering development work carried out by Househam's advanced engineering division and our vast experience in crop protection. Power, precision, stability and comfort, the **MERLIN** delivers everything you could want from a sprayer. And more.

The overall handling of the Merlin and its spraying capabilities are second to none. Great visibility, good handling and a very easy to operate work station make it a perfect option for us.

Steve Cole. Various crops from Asparagus and Blueberries to Wheat. 1500 acres owned and 1500 acres contracted.





A superbly equipped sprayer that ticks all the right boxes

When it comes to satisfying the most demanding operators and performing in the most challenging conditions the Househam **MERLIN** series of self-propelled sprayers tick all the right boxes. With a choice of 4000, 5000 or 6000 litre spray tanks and 200 or 300 litre fuel tanks, **MERLIN** has real staying power – and that means more time in the field and less time refilling. The choice of booms is equally impressive and the lower boom configuration results in a lower centre of gravity and outstanding stability when spraying.

Relatively light in weight and equipped with powerful, highly responsive Sauer Danfoss wheel motors, **MERLIN** delivers excellent traction through the gears even on wet, heavy and undulating terrain. The Air Ride suspension system provides automatic levelling and the unobstructed underbelly with higher ground clearance protects the most delicate of crops.

Reliable CAT engines, 170hp to 225hp depending on model, deliver all the power you need with excellent economy.

Add to all this one of the quietest and most comfortable cabs in the sprayer market and industry-leading control and GPS mapping technology, and it's easy to see why so many **MERLIN** owners wouldn't settle for anything less.



Central pivot back frame is standard across the MERLIN range



Sauer Danfoss wheel motors for increased power and reliability



Unobstructed underbelly and higher ground clearance



"The Househam Merlin is a complete solution to the modern day demands of crop husbandry. The fully integrated GPS, auto-section control and HITS enables me to maximise output, experience less driver fatigue and deliver greater accuracy when applying pesticides. All whilst assessing the crop carefully when travelling - a great all round machine in my opinion."

Christopher Hanks, V J Thomas & Son, Vale of Glamorgan – winter wheat, winter oats, spring barley, spring beans, maize, fodder beet, game strips and grassland desiccation

"Everything in the cab is easily laid out, the tilt steering column and excellent boom view out of the rear of the cab is a real bonus."

Donald and Philip Brown, all cereals crops - OSR, Maize, Beans and Oats grower, Berkshire



Excellent views of boom from the panoramic cab

Comfortably, the best cab in its class

When you spend so much time out in the field, a comfortable work-station is essential. Developed from the ongoing dialogue we have with our customers, the **MERLIN** cab is difficult to beat. A remarkably quiet, spacious, comfortable environment enhanced by climate control, adjustable steering column rake and air suspension seat ensures a smooth, effortless and stress-free ride. The ergonomic layout for steering and spraying functions places these controls within easy reach – just where they should be. And, in response to customer demand, foot pedals provide braking and throttle control as standard.

The panoramic cab design also affords excellent rear and side boom visibility when spraying.



Foot throttle and brake standard



Househam innovation puts you in complete control

Our unique control system, **Total Machine Control (TMC)**, developed by Househam engineers specifically for Househam sprayers, is standard across the **MERLIN** range. This intuitive, easy-to-use touch-screen console boasts impressive functionality including application rate control, engine management, monitoring and diagnostics, hydrostatic drive control and monitoring, integrated warning and fault detection and an automatic service reminder alert.

TMC provides the platform for Househam **FieldMaster GPS** technology, also developed in-house by the Househam advanced engineering division.

FieldMaster provides Field Mapping with exceptional accuracy, together with Light-Bar Guidance and Auto-Section Control in one user-friendly, touch-screen unit and is fully compatible with YARA N SENSOR, Farmade and SOYL mapping. Designed specifically for Househam sprayers, **FieldMaster** synchronises seamlessly with Househam's controls and other systems.



Fully integrated TMC control unit and FieldMaster GPS mapping system



The FieldMaster controls ten sections of the 36 metre boom. It is very near perfect spraying. I waste virtually nothing and the overspray, even on my peculiar shaped fields, is minimal. It certainly saves us money.

Ed Beckett, Beans, Barley, OSR grower, Stottesdon

A boom system that combines versatility, technology and stability

MERLIN is available with boom widths ranging from 24 to 36 metres. Standard 24m booms are of a flat fold design with fixed incline. Hydraulic incline is optional on these booms but is standard on our 30 – 36m triple-fold boom designs. This feature, which allows one boom wing to be inclined while the other one sprays, is a real bonus when negotiating obstacles in the fields. Recirculating booms are standard as are quick-acting air valves at the nozzle. So you get instant spray at the required pressure - no waiting for the pressure to build and no under-application on headlands.

"The excellent boom configuration, lower on the chassis, offers a lower centre of gravity and when spraying is superbly stable. It has good underbelly clearance – vital for the quality of crop we are producing – and a great machine to drive."

David Pridgeon. Malting Wheat, OSR, Spring Wheat, Malting Barley and Peas, Lincolnshire.



Auto Nozzle Select (ANS) and Boom Height Control

For those who want the ultimate in spraying precision, **MERLIN** sprayers are available with **Auto Nozzle Select (ANS)** and **Boom Height Control**. **ANS** offers constant and accurate application regardless of speed by selecting the nozzle required to keep application rates and pressure within a pre-set band. Full variable geometry **Boom Height Control** utilises five ultra-sonic sensors across the boom to ensure the boom follows contours both above and below the level area, further enhancing application accuracy.

MERLIN can also be specified with **Spray Pilot**. Fully integrated with **TMC FieldMaster** this hydraulically controlled system offers full hands-free steering with accuracy and efficiency.





"We have very mixed ground here, from very boggy to light and well drained, so it was important to have a machine that would give us good traction in all conditions. The Merlin answered this question immediately."

Colin Turner, Wheat, Barley, Potato, Onion, Beet and OSR grower.



Optional ultra-sonic boom levelling



Safety steps and excellent all-round lighting



Quick, easy access to reduced plumbing system



Safe, easy-to-use hopper and controls

Househam - the home of design innovation and advanced engineering

All Househam sprayers represent the very best of British design and engineering. The success of Househam Sprayers Group is built on a foundation of world-class technical innovation. This is the return on our investment in continuous research and development, rigorous testing regimes and an in-house manufacturing resource underpinned by exhaustive quality control assessments at every stage.

Advanced design and manufacture have been key in more than four decades of continued success on a global stage. But it's our people who really make the difference. Househam's designers and engineers are among the best in the agricultural sprayers industry. We work in close collaboration with customers and partners, not just in the UK, but across our international markets too. Keeping our fingers on the pulse of the industry in this way ensures we remain at the forefront of sprayer design and technology and continue to deliver highly innovative, effective and cost-efficient products for all our customers worldwide.



KEY FACTS AND FIGURES

• Choice of 3 Merlin models	• 170 - 225hp CAT Turbo Diesel engine*
• Spray tank capacity 4000 – 6000l*	• 200 - 300l fuel tank*
• Total Machine Control (TMC) with FieldMaster GPS mapping system	• 400l GRP clean water tank
• 13/24m flat fold steel boom with fixed incline and centre pivot back frame as standard	• 1m unobstructed underbody clearance
• Triple fold system with hydraulic incline on boom options from 30m to 36m	

*Depending on model selected

More features

Engine and Chassis

- 1.83m (72") - 2.13m (84") manually adjustable axles
- Foot brake and foot throttle
- Bent axis wheel motors with planetary gearbox
- Parking brake with integrated control of access ladder
- 380/85 R34 row crop wheels or 600/65 R28 flotation wheels
- Cyclone air cleaner
- Temperature controlled fan speed with auto-reverse function

Spray System and Booms

- Fully enclosed side mounted spray system with minimum pipework
- Fully clean system rinsing
- Altek 4 cylinder 260 l/min pump
- Suction filter and flushing pressure filter
- 3/4" (19mm) stainless steel spray lines
- Triplet nozzle bodies
- 30l stainless steel hopper with ProClean and ProClean + rinse jets
- 4 spray sections

MERLIN (M4-36) DIMENSIONS

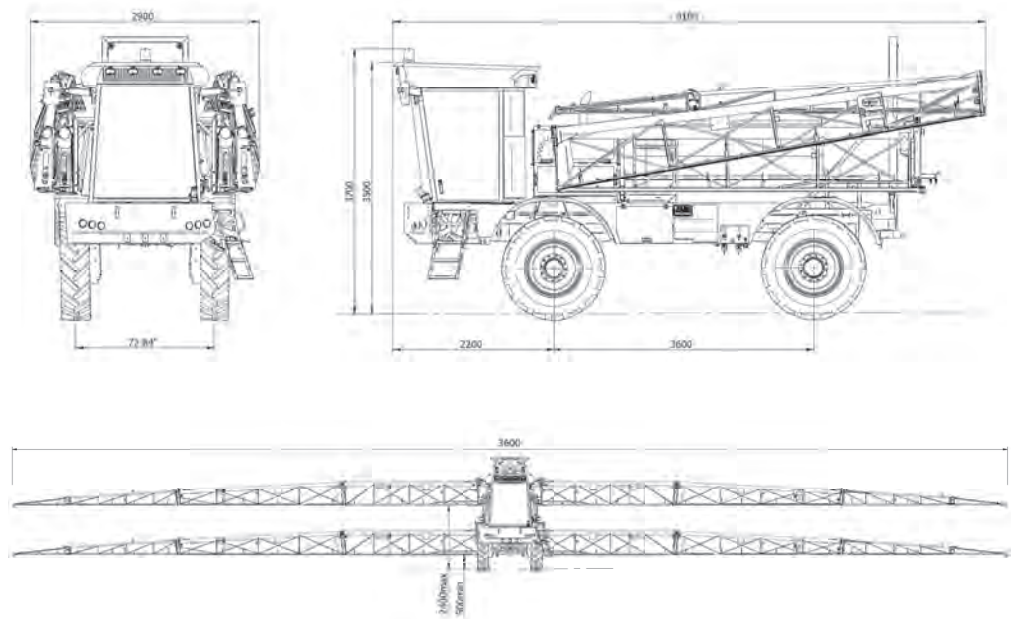

Find out more

For further information about the MERLIN or any other sprayer within the extensive Househam range, call us today on **01400 276050**.

