

Design innovation and advanced engineering

All Househam sprayers represent the very best of British design and engineering. Our designers and engineers are at the forefront of development in the agricultural sprayers industry. We work in close collaboration with customers and partners, not just in the UK, but across our international markets too. Keeping our fingers on the pulse of the industry in this way ensures we remain at the forefront of sprayer design and technology and continue to deliver highly innovative, effective and cost-efficient products for all our customers worldwide.



KEY FACTS AND FIGURES

• 4,000 or 5,000 litre stainless steel spray tank	• Michelin SprayBib 380/90 R46 rowcrop wheels or 650/60 R38 low ground pressure wheels
• 24/30/32 or 36 metre triple fold boom	• 1.1m under chassis clearance for rowcrop applications
• 230hp MTU 4R1000 power pack	• 72" (1.83m) - 84" (2.13m) axles manually adjustable
• 300ltr fuel tank	• Cat 4, fully air-conditioned cabin
• Clean water tank - 10% of spray tank capacity	• Roll-over protection tested and approved
• From factory, includes Platinum Service Cover for 3 years or 3000 hours, giving you increased uptime, full maintenance and preventive maintenance.	

More features

Spray System and Booms

- Single fill point for ease of operation when filling
- Tank contents sensors both spray and clean water tank
- Minimal pipework ensures efficient wash cycles and reduced maintenance
- Centrifugal spray pump
- 3/4" (19mm) stainless steel spray lines
- Quad multi-spray nozzle bodies
- Pantograph arm boom lift/lower
- Electronic ball valve selection - spray, fill, chemical induction function including auto-fill operational from the cabin and at side infill monitor

Cabin

- High back Grammer air suspension seat
- Fold down buddy seat
- DAB radio and CD with Bluetooth
- Removable cool box for food and drink storage
- Reversing camera

DIMENSIONS FOR PREDATOR 5000 WITH 36m BOOM

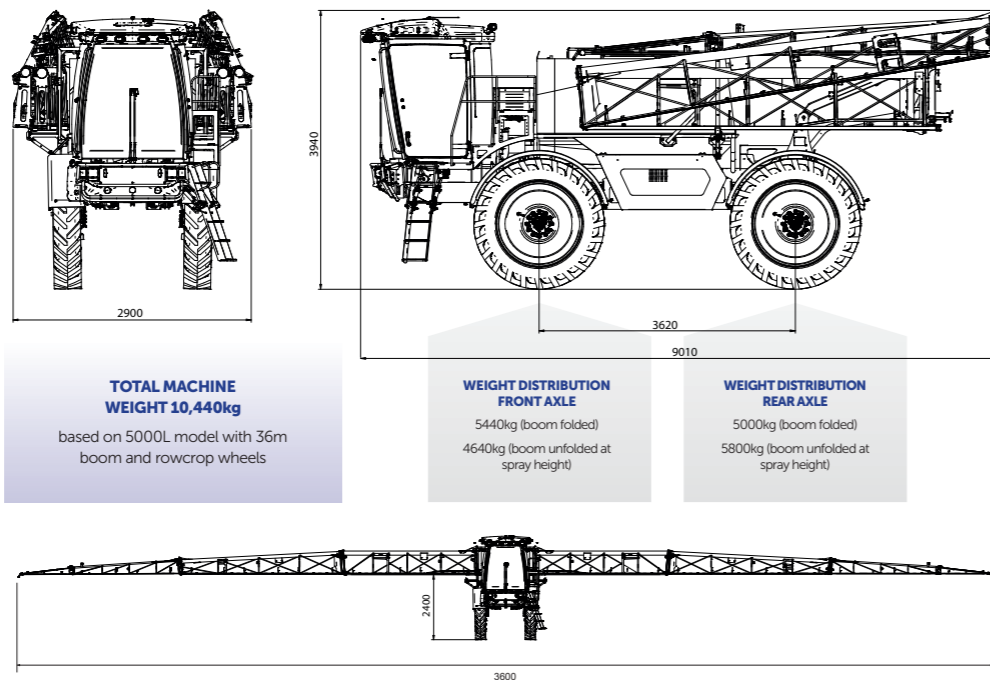

HOUSEHAM
SELF-PROPELLED SPRAYERS



PREDATOR

The new breed of self-propelled sprayer from Househam



HOUSEHAM

Find out more

For further information about the **PREDATOR** or any other sprayer within the extensive Househam range, call us today on **01400 276050**.



HOUSEHAM PREDATOR

Big on capacity, big on comfort, big on technology

The all-new **PREDATOR** from Househam is designed and built to meet the needs of farmers, contractors and operators in a big way. With capacities of 4,000 and 5,000 litres, twin-fold and tri-fold booms ranging from 24 to 36 metres and larger tank and boom sizes planned for the future, the **PREDATOR** features a new chassis developed for use with the latest large wheel and tyre equipment.



If you demand high capacity, high performance and the highest levels of technology and comfort from your self-propelled sprayer the new **PREDATOR** more than measures up to your expectations.

The biggest machine in the Househam self-propelled range, the **PREDATOR** can be fitted with Michelin SprayBib 380/90 R46 rowcrop tyres or Michelin 650/60 R38 tyres, with ground clearances of 1.10 and 1.05 metres respectively. Stability and manoeuvrability are first class and because the **PREDATOR** is lighter in weight than other similar size machines, ground pressure is significantly reduced.



The latest technology as standard

The **PREDATOR** comes with a host of factory-fitted advanced features including:-

- Individual Nozzle Control (INC)
- Auto Nozzle Select (ANS)
- Specially designed fully active hydraulic suspension
- Category 4, fully air-conditioned cabin
- Ultra-quiet operating environment with panoramic visibility
- Househam Total Machine Control (TMC) V5 controller
- Househam FieldMaster GPS mapping and guidance technology
- Load sense hydraulics for quieter, more efficient operation
- Househam Intelligent Transmission System (HITS) for regulation of maximum speed in both road and field modes
- Hill Assist feature assists when setting off or stopping on inclines
- Variable geometry boom levelling
- High output centrifugal pump with auto-priming

Power-packed performance with high efficiency

A 230hp 4-cylinder MTU engine provides all the power you need with outstanding fuel efficiency. The power unit is rear-mounted to optimise weight distribution. The **PREDATOR** is capable of road speeds of up to 50km/hr whilst, in the field, a 2-speed cruise control system further enhances machine operation and operator comfort.



PREDATOR utilises Michelin 380/90 R46 rowcrop tyres or, as shown here, a 650/60 R38 low ground pressure option.



Individual Nozzle Control for superb spraying accuracy and adaptability.

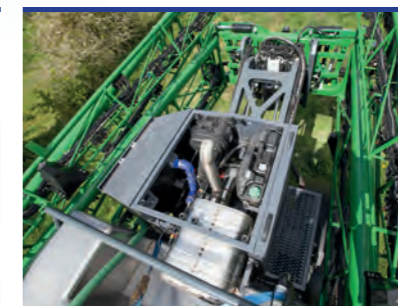

A powerful rear-mounted 230hp MTU engine optimises weight distribution and minimises cab noise and heat levels.



The quiet, spacious and luxuriously appointed cab is ergonomically designed to enhance operator comfort.



The 4-link fully active hydraulic suspension system is specially designed for the **PREDATOR**.



Easy-to-access side fill area, chemical induct at infill monitor and chemical hopper.



Househam's advanced TMC V5 controller and FieldMaster GPS system are included as standard.



High back Grammer air suspension seat plus fold-away buddy seat.